

APPLICATION:

JOB NAME:

QUANTITY:                      ITEM NO.

PRODUCT NAME:  
SERVICE SINK FAUCET, LONG SPOUT,  
ECCENTRIC STOPS AND VACUUM BREAKER

SPECIAL CONFIGURATION  
 CHECK BASE MODEL AND OPTIONS

MODEL:  
■ 8261

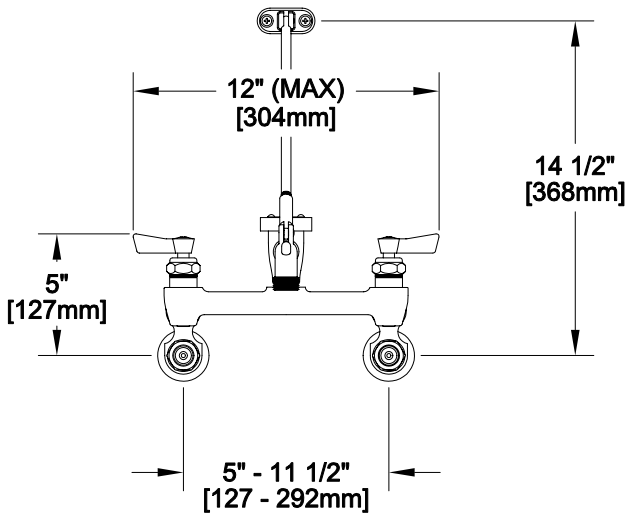

OPTIONS OR MODIFICATIONS:

SUPPLY LINES (24" OR 36") CIRCLE LENGTH

NIPPLES

ELBOWS

HANDLES (CROSS OR WRIST) CIRCLE STYLE

VANDAL RESISTANT KIT

OTHER \_\_\_\_\_

FEATURES

CONTROL VALVE

- \* KEY-STOP ECCENTRICS ADJUST FROM 5" TO 11 1/2"
- \* INTERNAL SPRING LOADED CHECK VALVES
- \* SWIVELLING SEAT DISKS
- \* HOT SIDE STEM - RIGHT HAND
- \* COLD SIDE STEM - LEFT HAND
- \* ECCENTRIC STEMS - RIGHT HAND SWIVEL
- \* STAINLESS STEEL SEATS
- \* STAINLESS STEEL SEAT SCREWS
- \* STAINLESS STEEL HANDLE SCREWS
- \* ATMOSPHERIC VACUUM BREAKER
- \* 3/4" GARDEN HOSE THREAD OUTLET

SYSTEM LIMITS

- \* TEMP: 40°F MIN. TO 140°F MAX.
- \* PRESSURE: 200 PSI MAX. STATIC
- \* 13.6 GPM AT 80 PSI

SHIPPING WEIGHT

- \* 7.5 LBS

ROUGH-IN:

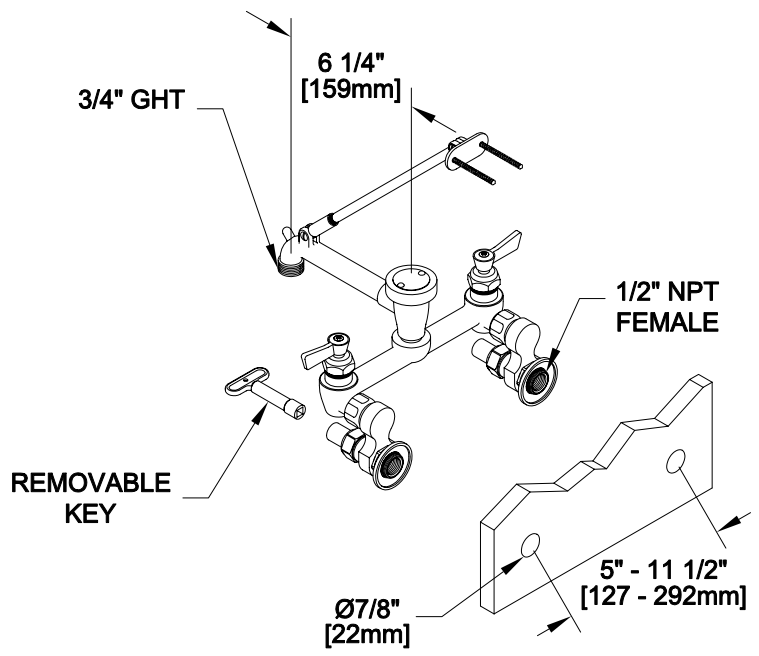

**FISHER**  
FISHER MANUFACTURING COMPANY  
TOLL FREE: 800-421-6162 - FAX: 800-832-8238  
information@fisher-mfg.com - www.fisher-mfg.com